

No. 737,984.

PATENTED SEPT. 1, 1903.

R. H. WHITE.
WATER REGULATOR.
APPLICATION FILED JULY 26, 1902.

NO MODEL.

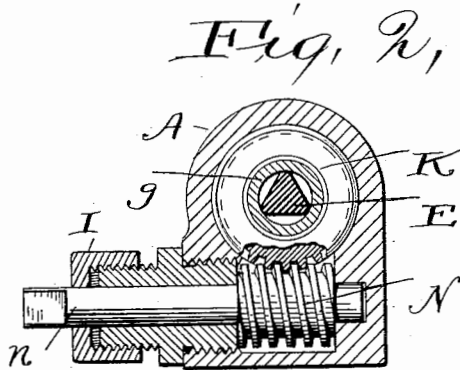
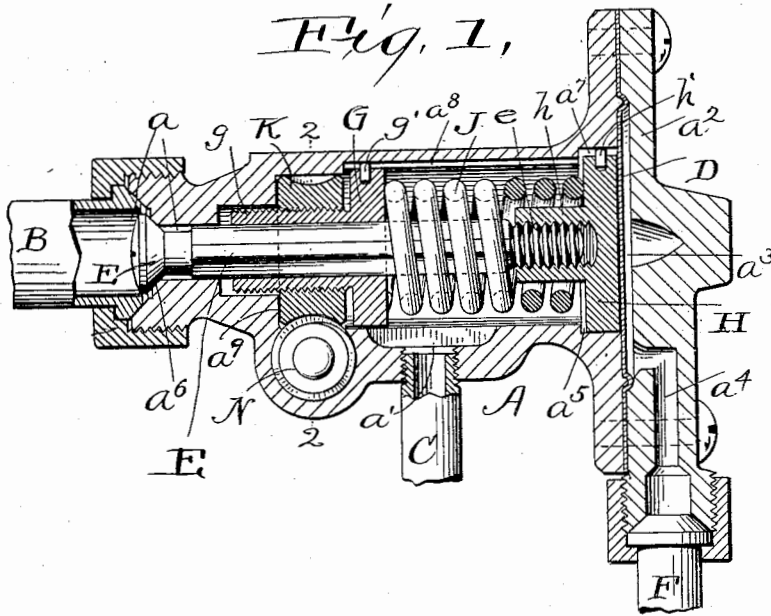

Witnesses.
E. B. Gilchrist
H. M. Wiss.

Inventor.
Rollin H. White,
By his Attorneys,
Thurston & Bates.

UNITED STATES PATENT OFFICE.

ROLLIN H. WHITE, OF CLEVELAND, OHIO, ASSIGNOR TO THE WHITE SEWING MACHINE COMPANY, OF CLEVELAND, OHIO, A CORPORATION OF OHIO.

WATER-REGULATOR.

SPECIFICATION forming part of Letters Patent No. 737,984, dated September 1, 1903.

Application filed July 26, 1902. Serial No. 117,080. (No model.)

To all whom it may concern:

Be it known that I, ROLLIN H. WHITE, a citizen of the United States, residing at Cleveland, in the county of Cuyahoga and State of Ohio, have invented a certain new and useful Improvement in Water-Regulators, of which the following is a full, clear, and exact description, reference being had to the accompanying drawings.

The invention relates to feed-water regulators adapted especially for use in connection with steam-generators of the flasher type and capable of being operated by the pressure of steam in the generator for the purpose of controlling the quantity of water fed to said generator.

The object of this invention is to provide a thoroughly practical device of the character specified which may without being taken apart or removed from its operative position be adjusted so as to operate at any desired steam-pressure to cut off the water-supply.

The invention, which is shown in the drawings and hereinafter described in detail, may be here summarized as consisting in the construction and combination of parts so shown and described, and definitely pointed out in the claims.

In the drawings, Figure 1 is a central longitudinal sectional view of a regulator device embodying my invention, and Fig. 2 is a transverse sectional view in the plane indicated by line 2 2 of Fig. 1.

Referring to the parts by letters, A represents a valve-casing of a convenient form having at one end a valve-controlled inlet a for water and at some suitable point an outlet a' for said water. A pipe, as B, which may be a branch of the pipe through which water is pumped to the generator, is secured over the inlet a , and a pipe C, which may return to the suction side of the pump or may go to the water-supply tank or may discharge at any other point as far as this invention is concerned, is connected with the outlet a' . The other end of the casing is closed by a cap-plate a^2 , whose edges clamp a flexible diaphragm D to the end of the casing. Between this diaphragm and the cap-plate there is a steam-chamber a^3 , which when the de-

vice is in operative relationship with the generator is connected with the steam-space in the generator by means of a port a^4 and a pipe F, connected therewith. In a rabbeted recess a^5 in the casing a disk H lies in substantial contact with said diaphragm, the rabbeted recess being somewhat wider than the thickness of the disk, so that the latter may have the necessary movement therein. The rotation of this disk must be prevented by means which will not interfere with the necessary movement of the disk lengthwise of the casing—as, for example, by a pin h' , which is secured to the disk and projects into a longitudinal groove a^7 in the casing. The disk H has on its inner side a threaded boss h , and the threaded stem e of the valve E screws into this boss to make an operative connection between the valve and this disk. The valve E, which is on the opposite end of the stem e , is of suitable shape—as, for example, conical—to fit the valve-seat a^6 at the end of the casing. Obviously the steam-pressure in the chamber a^3 upon the diaphragm D tends to open this valve. The opening movement of the valve is, however, resisted and the valve is seated by a coil-spring J, which surrounds the valve-stem and is compressed to a greater or less extent between the disk H and an adjustable disk G. The valve-stem passes through this last-named disk and its externally-threaded stem g ; but there is sufficient space around the stem for the water to pass. Within the casing and lying between the disk G and a shoulder a^9 on the casing is an adjusting-nut K, which screws onto the threaded stem g . On the outer periphery of this nut worm-teeth are cut, which teeth are engaged by a worm N, rotatably mounted in the casing and having an operative stem n , which passes out of the casing through a stuffing-box I. The rotation of the disk G is prevented, as by a pin g' , which is secured to the disk and projects into a longitudinal groove a^8 in the casing.

In assembling the described parts the valve-stem is screwed into the stem h until the valve will be seated, when the diaphragm D is in its normal condition and the disk H is in contact therewith. Then by turning the stem n

the nut K is rotated and the disk G moved until the tension on the spring is such that it will hold the valve closed until such time as the steam-pressure in the chamber a^3 has reached some predetermined maximum. If the spring loses power, as it may do because the valve-casing will be exceedingly hot during the operation of the device, the proper tension may be restored by turning the stem n , and by the same means the spring under all conditions may be put under such tension that it will hold the valve closed until there is any desired steam-pressure in the chamber a^3 . The two grooves a^7 a^8 extend to one end of the casing, and thereby the assembling of the parts is facilitated.

Having described my invention, I claim—

1. The combination of a casing having a steam-inlet port, a water-inlet and a water-outlet, a flexible diaphragm, a valve for closing the water-inlet and adapted to be opened by that movement of said diaphragm which is produced by the steam-pressure, a spring operating to hold said valve closed and means within the casing capable of being operated from the outside for changing the tension of said spring, substantially as described.

2. The combination of a valve-casing having a steam-inlet port, a water-inlet and a water-outlet, and a flexible diaphragm, a movable disk in contact with the water side of said diaphragm, a valve for closing the water-inlet operatively connected with said disk, a spring engaging at one end with said disk, a movable tension-disk engaging with the other end of the spring and having an externally-threaded stem, a worm-nut in the casing upon said stem, and a worm mounted in the casing engaging with said worm-nut, substantially as specified.

3. The combination of a valve-casing having in one end a water-inlet surrounded by a valve-seat, and having near the other end a steam-inlet port, a flexible diaphragm secured across the valve-casing between said two

ports, there being, in said casing on the water side of the diaphragm, a water-outlet, a non-rotatable disk H having a threaded stem h , a valve for closing the water-inlet and having a stem which passes through said inlet and screws into the threaded stem of the disk H, a longitudinally-movable non-rotatable disk in the casing loosely embracing said valve-stem and having an externally-threaded stem, a worm-nut within the casing upon said threaded stem, a shoulder in the casing against which said nut abuts, and a worm mounted in the casing and having a stem which extends outside of the casing, substantially as specified.

4. The combination of a valve-casing having through one end a water-inlet, and around said inlet an internal shoulder and an external valve-seat, and having at the other end a rabbeted annular recess, a flexible diaphragm across the last-named end of said casing, a cap closing this end of the casing and clamping the diaphragm thereto, and containing a steam-port, said casing having also the internal longitudinal grooves a^7 a^8 , a disk H in said rabbeted recess and having a projection entering the groove a^7 , a tension-disk G having a projection which enters the groove a^8 , and a threaded stem, a worm-nut on said threaded stem between the disk G and the internal shoulder of the casing, a worm mounted in the casing and engaging with said worm-nut, a spring compressed between the disks H and G, and a valve, whose stem passes loosely through the water-inlet and tension-disk and screws into the disk H, there being a water-outlet a' in the casing, substantially as and for the purpose specified.

In testimony whereof I hereunto affix my signature in the presence of two witnesses.

ROLLIN H. WHITE.

Witnesses:

E. B. GILCHRIST,
E. L. THURSTON.