

F. E. STANLEY.
CROSS HEAD.

(Application filed Oct. 6, 1900.)

(No Model.)

2 Sheets—Sheet 1.

Fig. 1.

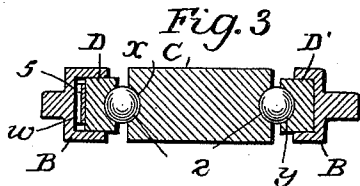
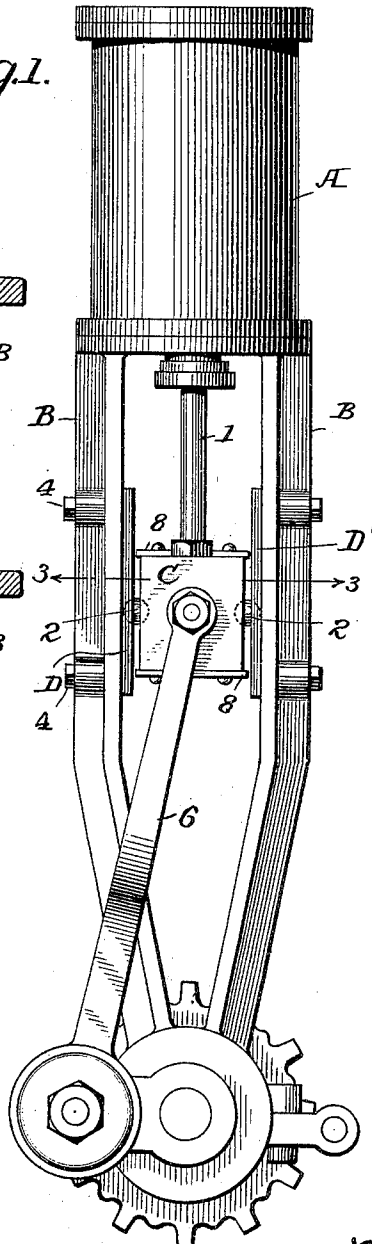
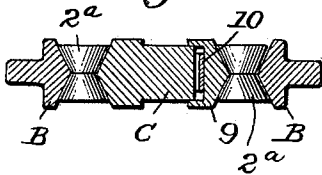

Fig. 4.



Inventor
Francis E. Stanley

Witnesses

J. G. Hinkel
H. L. Ogdun

By *Lucius Freeman* Attorneys

F. E. STANLEY.
CROSS HEAD.

(Application filed Oct. 6, 1900.)

(No Model.)

2 Sheets—Sheet 2.

Fig. 2.

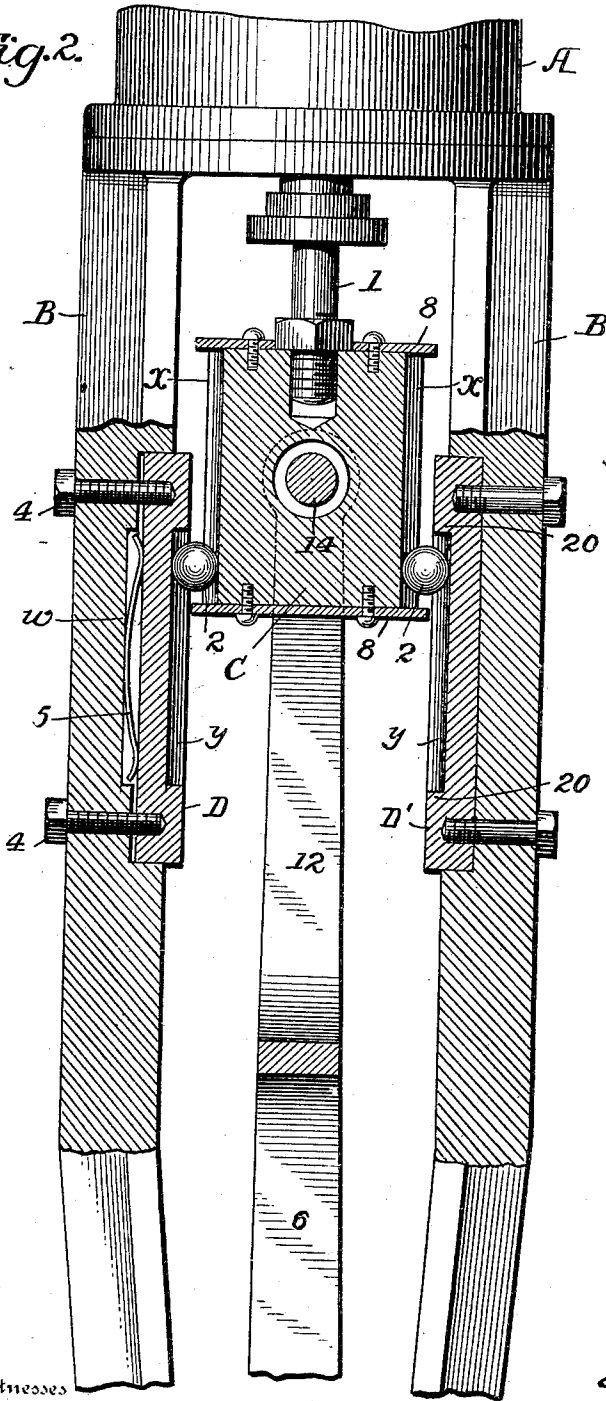
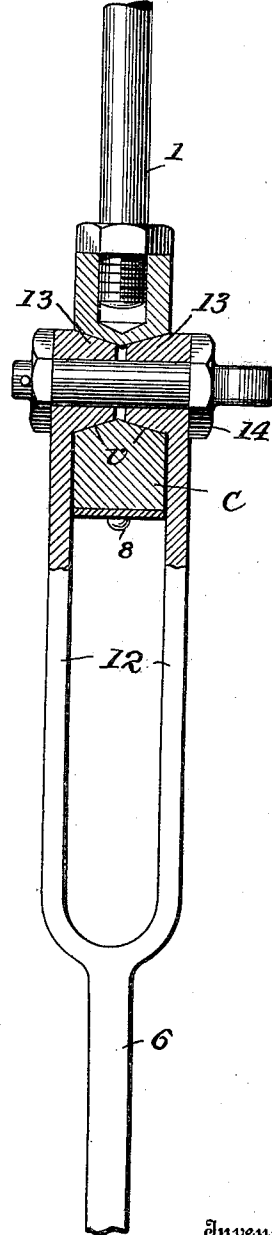

Fig. 5.



Witnesses

J. F. Hinkel
H. S. Ogden

Inventor

Francis E. Stanley

By

Forster & Freeman Attorneys

UNITED STATES PATENT OFFICE.

FRANCIS E. STANLEY, OF NEWTON, MASSACHUSETTS, ASSIGNOR OF ONE-HALF TO FREELAN O. STANLEY, OF SAME PLACE.

CROSS-HEAD.

SPECIFICATION forming part of Letters Patent No. 672,337, dated April 16, 1901.

Application filed October 6, 1900. Serial No. 32,306. (No model.)

To all whom it may concern:

Be it known that I, FRANCIS E. STANLEY, a citizen of the United States, residing at Newton, in the county of Middlesex and State of Massachusetts, have invented certain new and useful Improvements in Cross-Heads, of which the following is a specification.

My invention relates to the cross-heads of motors or other apparatus; and it consists in certain means whereby to reduce the friction between the cross-head and its guides and to take up wear, as fully set forth hereinafter and as illustrated in the accompanying drawings, in which—

Figure 1 is a side view of an engine embodying the invention. Fig. 2 is an enlarged sectional view of a part of an engine sufficient to illustrate my improvements; Fig. 3, a section on the line 3 3, Fig. 1; Fig. 4, a similar section illustrating certain modifications; Fig. 5, a longitudinal section of the cross-head and connecting-rod.

The engine-cylinder A is suitably connected with the guide from B, and the cross-head C is connected with the piston-rod 1 and travels between the guides D D', which may be formed on or connected with the frame B. Between the bearing edges of the guides and cross-head are rollers 2, which may be in the form of spheres fitting grooves *x* of the cross-head as well as corresponding grooves *y* in the guides D D' and constituting the roller-bearings of the cross-head. The rollers, however, may be of other forms—for instance, they may be disks with peripheral grooves to receive the V-shaped bearing edges of the cross-head and guides, as shown in Fig. 4.

There should be at some part of the apparatus means for causing a yielding bearing of the parts upon the rollers which will insure a constant pressure upon the rollers between the guiding or bearing faces of the cross-head and guides, so that while the cross-head can reciprocate freely between the guides and while the rolls can travel upon the guides and the cross-head upon the rolls with practically no frictional resistance there will yet be sufficient friction upon the rolls in consequence of said pressure to prevent the rolls from falling or moving between the parts ex-

cept by rolling on the bearing-faces, while pressure is maintained upon the rolls notwithstanding any wear or slight irregularities of construction.

Different means may be employed for maintaining a pressure upon the rolls between their bearings. As shown in Figs. 1, 2, and 3, the guides D D' are separate from the frame B, the front guide D' being bolted fixedly to the frame, while the rear guide D is supported by bolts 4 4, sliding in the frame, and is forced toward the cross-head by means of a spring 5, held within a recess *w* of the frame. The spring 5 is so stiff that the guide D will not yield to the pressure resulting from the thrust of the connecting-rod 6 extending to the pin or crank of the shaft; but in case of wear or any irregularity in fitting the parts the spring forcing one roll against the cross-head and the latter against the other roll will maintain the contact of the rollers with their bearing-faces.

It is of course possible that under certain conditions a roller may slip between its bearings and would pass beyond the end of the cross-head if provision were not made to prevent this result. I therefore extend the guides beyond the limits of travel of the cross-head and provide the cross-head with projections which will be brought against a roller if the latter becomes displaced. As shown, these projections are the ends of plates 8 8, which are bolted to the ends of the cross-head projecting beyond the bearing edges thereof, so as to make contact with the rollers under the conditions named. If, then, a roll should fall during, say, the upward movement of the cross-head, it would be held against the cross-head by the opposite guide and would be arrested by the projecting end of the lower plate 8 and would then be carried upward until the piston reached the limit of its upward movement, when on the descent of the cross-head the roller would roll between its bearings in a proper manner. There are also shoulders or stops 20 upon the guides which prevent the rollers from traveling beyond their proper limits of movement on said guides.

While I have shown the back guide as hav-

ing a yielding bearing, the front guide, or both, may be thus provided or the yielding bearing may be upon the cross-head, as indicated in Fig. 4, where a separate edge portion 9 of the cross-head is seated on a spring 10.

The connecting-rod 6 may be pivoted or jointed to the cross-head in any suitable manner; but in order to compensate for the wear which is likely to occur at this point and to prevent all looseness or rattling of the parts I make the connecting-rod with a forked end, the branches 12 12 of the fork having at their inner sides lugs 13, with external annular conical faces *v* adapted to the opposite flaring ends of a transverse opening or recess in the cross-head, and by drawing together the forks or branches 12 by means of a cross-bolt 14 the contact of the cross-head bearings and connecting-rod bearings is maintained. The cross-bolt is smaller in diameter than the opening, so that it will not prevent the lugs from taking their bearings against the faces of the conical recesses when the lugs wear away.

Without limiting myself to the precise construction and arrangement of parts shown, I claim—

1. The combination of a cross-head, a fixed and a movable guide, two intermediate rollers, and means for forcing the movable guide

with a yielding pressure against its roller, substantially as set forth.

2. The combination of a cylinder, guide-frame, reciprocating cross-head, guides supported by the frame, one fixedly and the other movably, a roller intermediate the cross-head and each guide, and means for forcing the movable guide with a spring-pressure toward the cross-head, substantially as set forth.

3. The combination of a reciprocating cross-head, guides extending at each end beyond the limit of travel of the cross-head bearings, a roller constituting the bearing between each guide and the cross-head, and projections on the cross-head arranged to engage the rollers if displaced, substantially as set forth.

4. The combination of the cross-head, guides extending beyond the limits of travel of the cross-head bearings and with shoulders 20, spring-bearings for one of the guides, intermediate rollers, and plates 8, 8 with projecting ends, substantially as set forth.

In testimony whereof I have signed my name to this specification in the presence of two subscribing witnesses.

FRANCIS E. STANLEY.

Witnesses:

W. F. BACON,
E. L. BACON.