

F. E. STANLEY.  
VAPOR BURNER.

APPLICATION FILED NOV. 9, 1903.

Fig. 1.

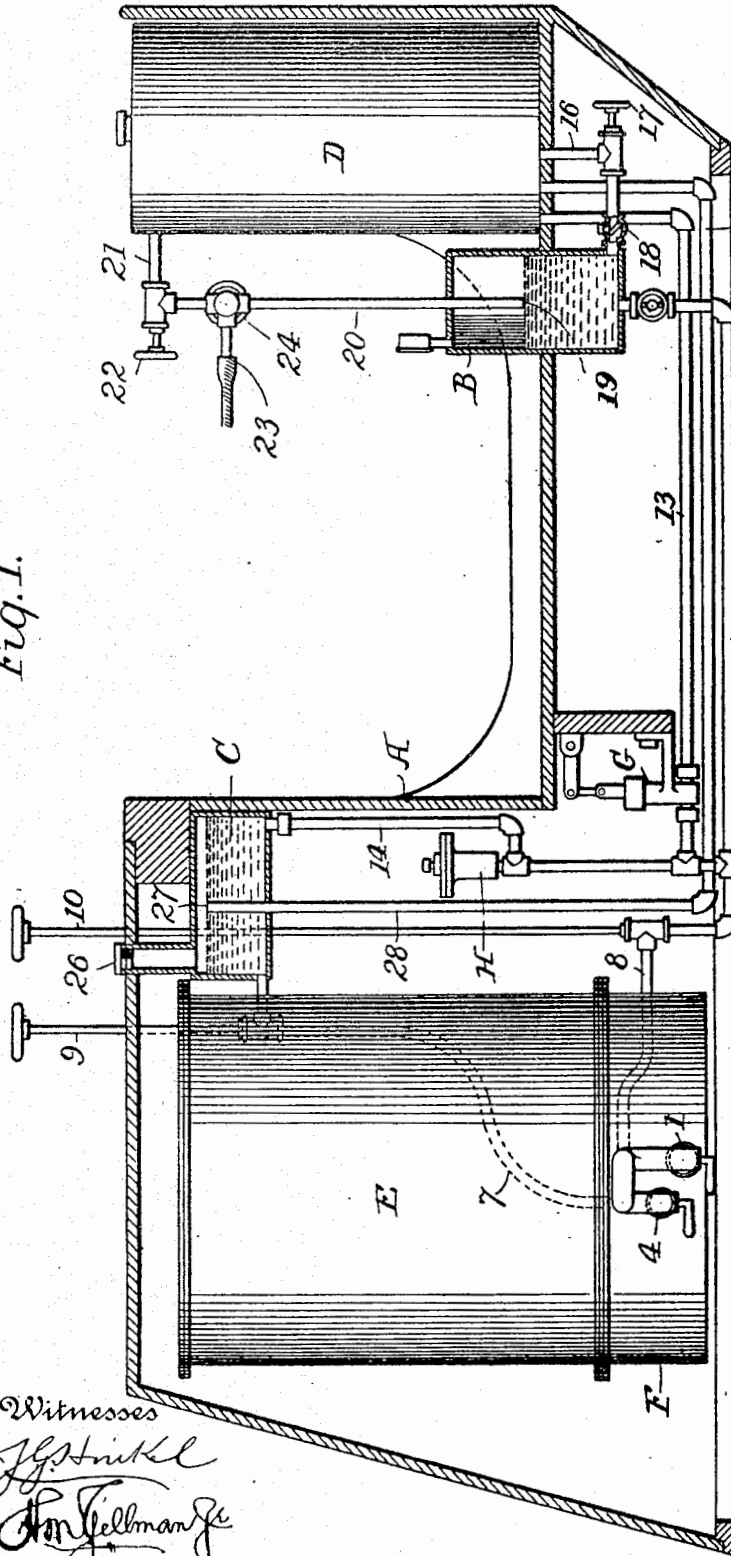
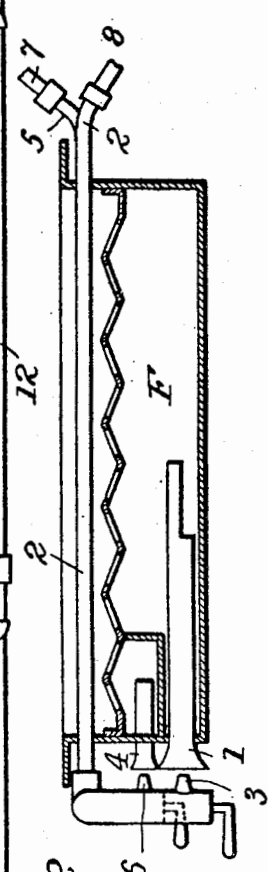

Fig. 2.



Witnesses  
*J. G. Hinkel*  
*Wm. Sellman Jr.*

Inventor  
*Francis E. Stanley*  
By *Walter Truman Watson*  
Attorneys

# UNITED STATES PATENT OFFICE.

FRANCIS E. STANLEY, OF NEWTON, MASSACHUSETTS.

## VAPOR-BURNER.

No. 797,623.

Specification of Letters Patent.

Patented Aug. 22, 1905.

Application filed November 9, 1903. Serial No. 180,411.

*To all whom it may concern:*

Be it known that I, FRANCIS E. STANLEY, a citizen of the United States, residing at Newton, in the county of Middlesex and State of Massachusetts, have invented certain new and useful Improvements in Vapor-Burners, of which the following is a specification.

My invention relates to that class of apparatus in which a vapor-burner has a main burner and a pilot-burner; and it consists in means whereby to supply the said burners independently with liquid fuel and in certain details of construction of the apparatus, as fully set forth hereinafter and as illustrated in the accompanying drawings, in which—

Figure 1 represents one arrangement of the parts of an apparatus embodying my invention, some of the parts in section; and Fig. 2 is a transverse section through the burner.

In the drawings I have illustrated arrangements of the parts embodying my improvements in connection with the frame A of a motor-vehicle, although they may be used in different arrangements for other purposes, there being a supply-tank D, a pressure-tank B, a supplemental tank C, a boiler E, and a burner F. These parts may be of different constructions and of different arrangements, except as hereinafter provided.

As shown, the burner F has slits or openings at the top and a mixing-tube 1, into which vapor is injected from a vaporizer 2 through a nozzle 3, and a part of the main burner is partitioned off to receive a second mixing-tube 4, into which vapor from an independent vaporizer 5 is injected through a nozzle 6 to constitute a section which forms a pilot-burner that will heat both the vaporizers 2 and 5 when the main-burner section is not ignited. Pipes 7 and 8 lead to the two vaporizers and are provided with hand-valves 9 and 10, arranged in convenient positions. The vaporizer of the main burner communicates, through a pipe 12, with the discharge-pipe of the pump G, the latter receiving liquid fuel from the supply-tank D through a pipe 13, and with the pipe 12 also communicates the pressure-tank B, into which liquid is forced from the pump G, compressing the air in the tank B, the valve 22 being closed. The maximum pressure in the tank B depends upon the adjustment of an ordinary regulating or by-pass valve H, which also communicates with the discharge-pipe of the pump and from which a pipe 14 leads to the supplemental tank C, which will receive the liquid discharged

by the pump when the pressure in the tank B is such that the by-pass valve opens, these operations being as usual, except the use of the tank C, in this class of mechanism.

Instead of providing a hand-pump for supplying the pressure-tank B before starting, as heretofore, I arrange the pressure-tank with such relation to the supply-tank that the liquid in the latter can pass into the pressure-tank by gravity. Thus a pipe 16 connects the lower parts of the tanks D B and is provided with a cock or valve 17 and check-valve 18, so that on opening the valve 17 any fluid in the tank D will pass into the tank B, the latter being provided with a port 19, through which air can escape as the fluid flows into the pressure-tank. As shown, the port 19 is at the lower end of a pipe 20, extending into the pressure-tank to such a distance below the top of the latter as to form an air-chamber, the pipe 20 communicating through a branch 21 with the air-space of the tank D and being provided with a hand-valve 22, which is closed after the tank B is supplied with oil. There is also a branch 23, closed by a hand-valve 24, adapted for connection with the flexible pipe of an air-pump, and by means of which air may be forced into the pressure-tank B to secure an initial pressure. The communication with the upper part of the tank D permits the escape of air from the tank D (the valves 22 and 24 being open) and insures that any liquid in the pipe 20 forced upward from the tank B shall be discharged into the tank D instead of escaping and being lost, the air-valve being then closed. The communication of the tank B with the tank D, however, is not otherwise essential and may be omitted. It will be seen that as the port 19 is arranged below the top of the pressure-tank it is impossible for the liquid flowing by gravity into the pressure-tank to exceed the predetermined level at which the port is arranged, so that when the pump starts in operation and additional liquid is forced into the pressure-tank there will be a closed space above the surface of the liquid, constituting an air-pressure chamber.

Heretofore in this class of apparatus the main burner and the pilot-burner have been supplied from the pressure-tank with the objections, among others, that when the vehicle is standing and the main burner shut off the pressure in the pressure-tank becomes gradually reduced, so as not to operate effectively with the main burner on again starting, while

as the pressure-tank is of necessarily-limited capacity it is difficult to maintain the pilot-light burning for any extended length of time. Another objection is that the opening in the nozzle of the pilot-burner when the latter is supplied under high pressure must be made so small that it is apt to become readily clogged by particles of carbon. To avoid these objections, I supply the pilot-burner from the supplemental tank C, the liquid in which may be under very little pressure, or, as shown, the said tank may be arranged at such a height that the liquid will pass to the pilot-burner by gravity alone. By this arrangement I am enabled to make use of a supplemental tank of any desired capacity that will keep the pilot-burner in action for many hours without reducing the pressure in the tank B, which supplies the main burner, and I can make use of a nozzle for the pilot-burner having a much larger bore than would otherwise be employed that will permit the passage of small particles of carbon and which has little liability to clog.

The tank C may be supplied in any suitable manner; but, as before described, may be in communication with the discharge-pipe 14, leading from the regulating-valve H, and may have a neck provided with a plug 26, through which it may be filled in the first instance.

Inasmuch as the liquid discharged through the pipe 14 in the ordinary operations of the machine will exceed the capacity of the tank C and does not flow of necessity regularly but intermittently, I insure a practically uniform supply of liquid in the tank C by providing the latter with an overflow-port 27 near the top, which communicates with the return branch 28 of the by-pass pipe leading back to the supply-tank. As shown, the pipe 28 extends into the tank C, with the port 27 at the upper end.

Without limiting myself to the precise construction and arrangement shown, I claim as my invention—

1. The combination with a vapor-burner, of a supply-tank, a pressure-tank arranged on a level below that of the supply-tank, connections whereby the contents of the supply-tank may be caused to flow by gravity to the pressure-tank, means to prevent a reverse flow, a pump connected to receive liquid from the supply-tank and discharge it into the pressure-tank, and a conduit having a port arranged to limit the upward flow of liquid in the pressure-tank and communicating with an inlet adapted to be connected with an air-pump, substantially as set forth.

2. The combination with a vapor-burner, of a supply-tank, a pressure-tank communicating with the supply-tank at both the top and bottom and arranged on a level below that of the supply-tank, whereby the pressure-tank may be supplied by gravity from the supply-tank,

a pump connected to receive liquid from the supply-tank and discharge it into the pressure-tank, a conduit having a port arranged to limit the upward flow of liquid in the pressure-tank and communicating with an inlet adapted to be connected with an air-pump, and means for closing the communication between the tanks at both top and bottom, substantially as set forth.

3. The combination with the main and pilot burners of a vapor-burner, of a supply-tank, a pump communicating with said tank and main burner, a return or by-pass pipe extending around the pump and having a relief-valve, and a supplemental tank in the line of the by-pass pipe, said latter tank communicating with the pilot-burner to supply the latter, substantially as set forth.

4. The combination with the main and pilot burners of a vapor-burner, of a supply-tank, a pump communicating with said tank and main burner, a return or by-pass pipe extending around the pump and having a relief-valve, and a supplemental tank in the line of the by-pass pipe, said latter tank arranged at an elevation to supply the pilot-burner by gravity, substantially as set forth.

5. The combination with the main and pilot burners of a vapor-burner, of a supply-tank, a pump communicating with said tank and main burner, a return or by-pass pipe extending around the pump and having a relief-valve, and a supplemental tank in the line of the by-pass pipe, said latter tank arranged above and communicating with the pilot-burner, and the return-section of the by-pass pipe extending upward to near the top of the supplemental tank, substantially as set forth.

6. The combination with the vapor-burner and supply-tank, of a pressure-tank in communication with the burner-supply pipe, and arranged to receive liquid fuel by gravity from the supply-tank, through a channel provided with a cock, a pipe connecting the upper portions of the two tanks and provided with a valve, and a pump, receiving fuel from the supply-tank and communicating with and maintaining pressure in the pressure-tank, substantially as set forth.

7. The combination with the vapor-burner, and supply-tank of a pressure-tank in communication with the burner-supply pipe, and arranged to receive liquid fuel by gravity from the supply-tank, through a channel provided with a cock, a pipe connecting the upper portions of the two tanks extending to a point below the top of the pressure-tank, and provided with a valve, and means for securing and maintaining pressure in the pressure-tank, substantially as set forth.

8. The combination of the main and pilot burners of a vapor-burner, a supply-tank, a pump communicating with said tank and main burner, a relief-valve arranged to open under excessive pressure from the pump, and a sup-

plemental tank receiving the liquid fuel passing from the relief-valve and arranged above and communicating with the pilot-burner, substantially as set forth.

9. The combination of the main and pilot burners of a vapor-burner, a supply-tank, a pump communicating with said tank and main burner, a relief-valve arranged to open under excessive pressure from the pump, and a supplemental tank receiving the liquid fuel passing from the relief-valve and arranged above and communicating with the pilot-burner and also communicating with the supply-tank through a port near the top of the supplemental tank, substantially as set forth.

10. The combination of the main and pilot burners of a vapor-burner, a supply-tank, a pump communicating with said tank and main burner, a relief-valve arranged to open under excessive pressure from the pump, a supplemental tank receiving the liquid fuel passing from the relief-valve and arranged above and communicating with the pilot-burner, and a

pressure-tank communicating with the pump and with the pipe leading to the main burner, substantially as set forth.

11. The combination of the main and pilot burners of a vapor-burner, a supply-tank, a pump communicating with said tank and main burner, a relief-valve arranged to open under excessive pressure from the pump, a supplemental tank receiving the liquid fuel passing from the relief-valve and arranged above and communicating with the pilot-burner, a pressure-tank communicating with the pump and with the pipe leading to the main burner, and hand-controlled valves controlling the flow from the supplemental and pressure tanks to the burners, substantially as set forth.

In testimony whereof I have signed my name to this specification in the presence of two subscribing witnesses.

FRANCIS E. STANLEY.

Witnesses:

J. W. BACON,  
J. H. GILKEY.