

G. E. WHITNEY.
MOTOR VEHICLE.

(Application filed June 9, 1899.)

(No Model.)

3 Sheets—Sheet 1.

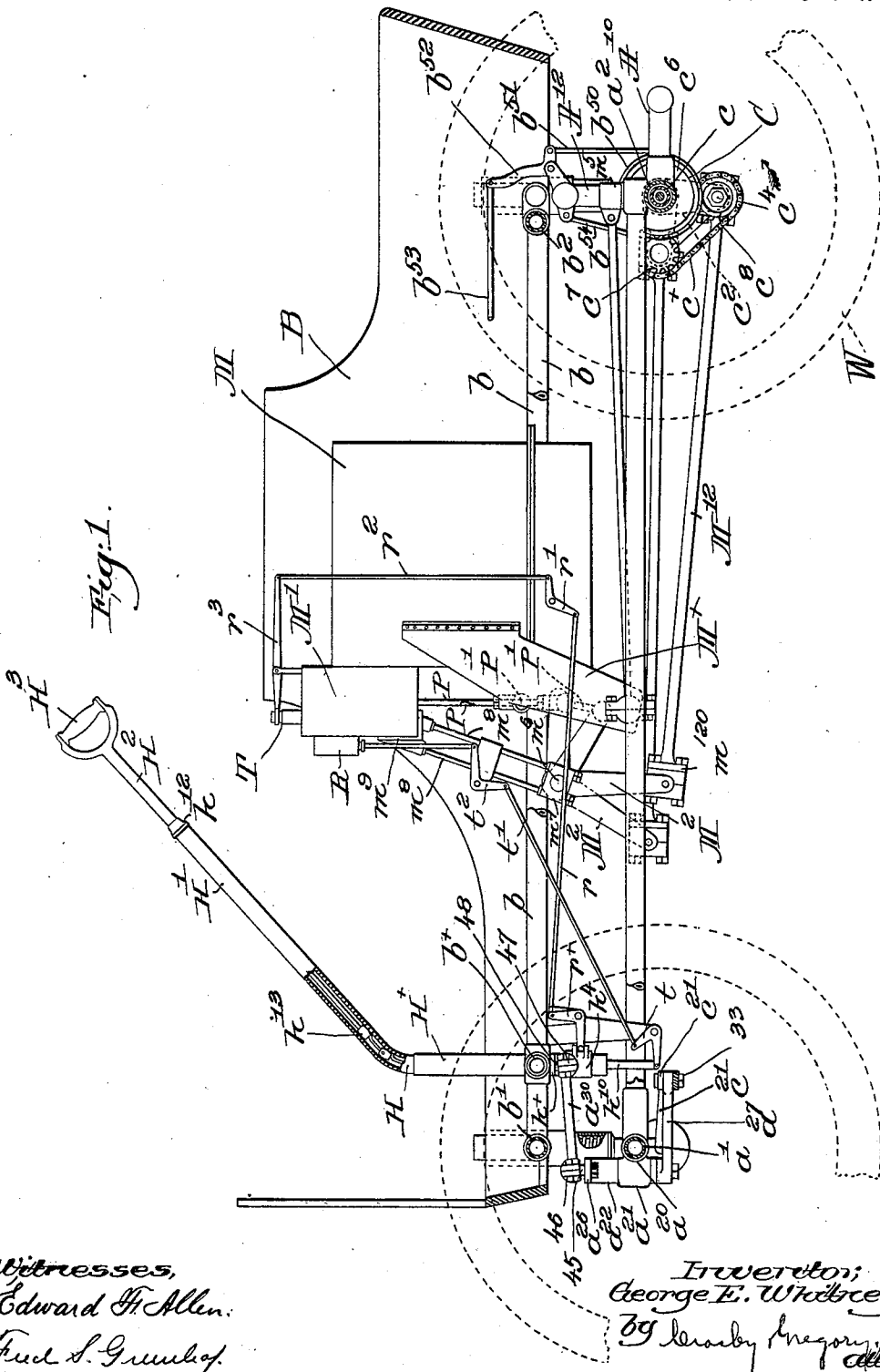

Witnesses,
 Edward H. Allen,
 Fred S. Grumbel.

Inventor;
 George E. Whitney,
 by Lewis Gregory,
 atty.

G. E. WHITNEY.
MOTOR VEHICLE.

(Application filed June 9, 1899.)

(No Model.)

3 Sheets—Sheet 2.

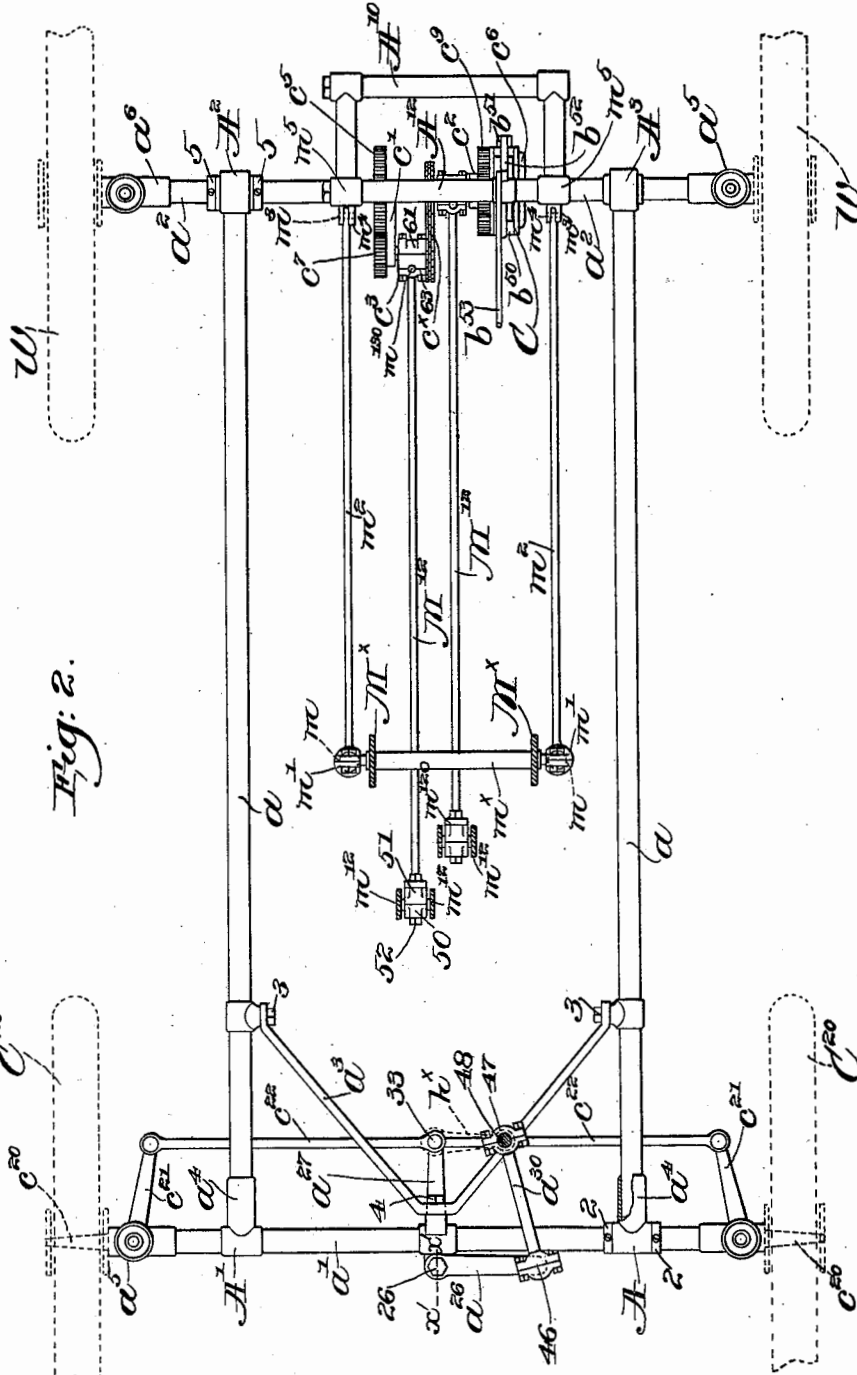

Fig. 2.

Witnesses:
 Edward H. Allen
 Gustave F. Magnitzky

Inventor:
 George E. Whitney
 by Crosby, Gregory,
 Attys.

G. E. WHITNEY.
MOTOR VEHICLE.

(Application filed June 9, 1899.)

(No Model.)

3 Sheets—Sheet 3.

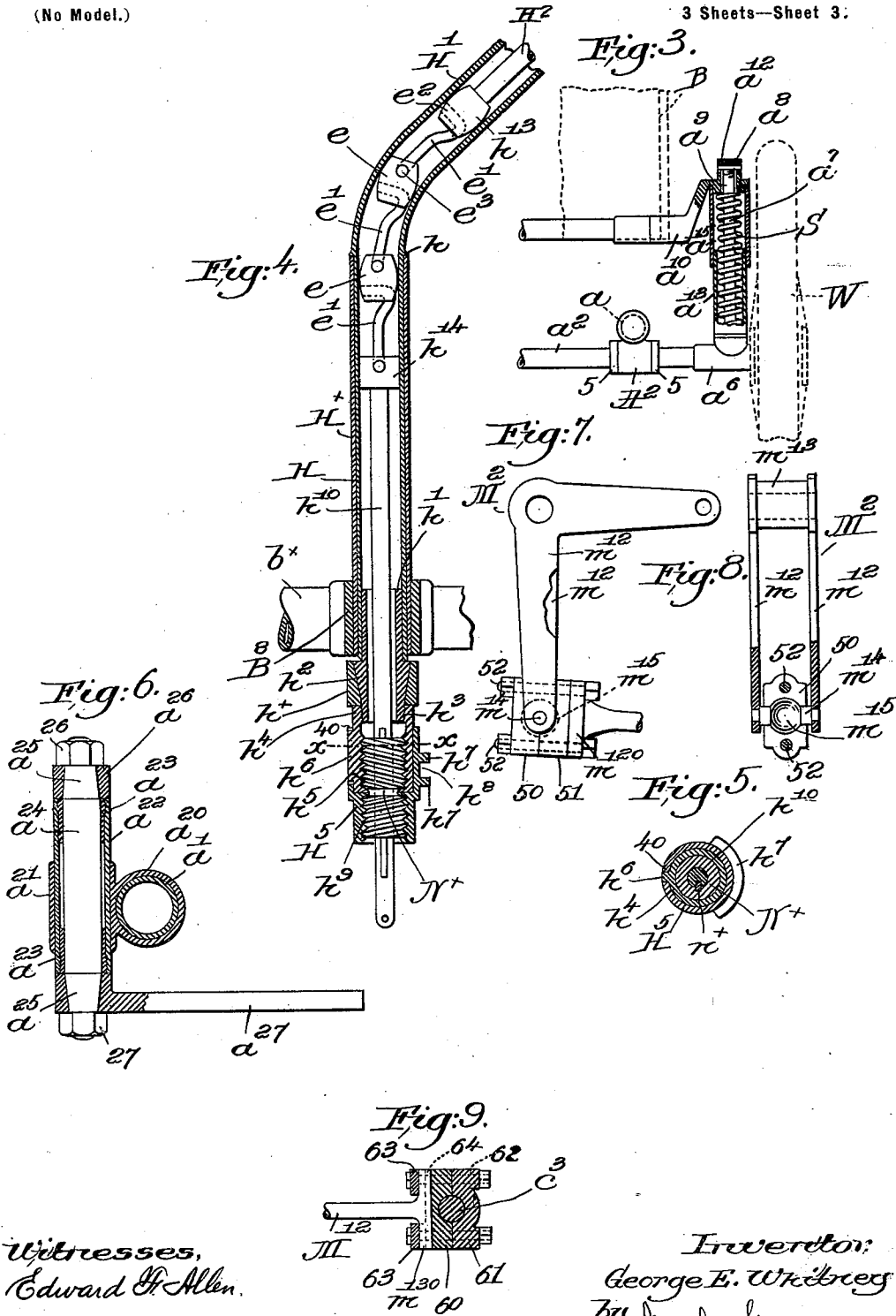

UNITED STATES PATENT OFFICE.

GEORGE E. WHITNEY, OF BOSTON, MASSACHUSETTS, ASSIGNOR TO THE
WHITNEY MOTOR WAGON COMPANY, OF SAME PLACE.

MOTOR-VEHICLE.

SPECIFICATION forming part of Letters Patent No. 652,942, dated July 3, 1900.

Application filed June 9, 1899. Serial No. 719,876. (No model.)

To all whom it may concern:

Be it known that I, GEORGE E. WHITNEY, of Boston, county of Suffolk, State of Massachusetts, have invented an Improvement in
5 Motor-Vehicles, of which the following description, in connection with the accompanying drawings, is a specification, like letters and numerals on the drawings representing like parts.

10 This invention relates to automobile or motor vehicles; and it has for one of its objects the production of a vehicle of the class referred to wherein the motor may be run at a comparatively-slow speed, thus reducing the
15 wear and tear of the motor and greatly extending its life. Again, the actuating connections in my present invention between the motor and driving-wheels are substantially free from injury by mud or dust, and the
20 parts are better protected from wear due to the action of grit and dust than is a sprocket-chain or other geared connection commonly employed to transmit power from the motor to the driving-wheels of the vehicle.

25 Other novel features of my invention will be hereinafter described in the specification, and particularly pointed out in the following claims.

30 Figure 1 in side elevation and partial section represents a motor-vehicle embodying one form of my invention, the side of the body and the wheels nearest the observer being omitted to clearly show the important parts of the apparatus. Fig. 2 is a top or plan view
35 of the main frame shown in Fig. 1, the driving and steering wheels being partly indicated by dotted lines, the auxiliary frame, motor, and body being omitted; but I have shown in Fig. 2 the connection between the motor and
40 the crank driving-shaft and also the distance members, to be described. Fig. 3 is a detail in end elevation and partial section, showing a convenient manner of yieldingly connecting the main and auxiliary frames, the body of
45 the vehicle resting upon the latter. Fig. 4 is an enlarged longitudinal sectional view of a part of the steering-head shown in Fig. 1 and the parts contained therein. Fig. 5 is a transverse section taken on the line $x x$, Fig. 4.
50 Fig. 6 is an enlarged longitudinal sectional view of the vertical rock-shaft mounted on

the main frame, taken on the line $x' x'$, Fig. 2. Fig. 7 is an enlarged side elevation of one of the actuating members of the motor, showing the universal joint between said member
55 and one of the connecting-rods. Fig. 8 is a right-hand end elevation of said actuating member, a part of it being shown in section and with one of the socket members removed to show the ball member of the joint carried
60 by the actuating member; and Fig. 9 represents in section one of the crank-pins of the driving-shaft and the journal-box surrounding the latter and also illustrating the transverse joining of the connecting-rod to the box.
65

I have herein shown the vehicle as comprising a two-part frame and a removable body, the two parts of the frame being hereinafter designated as the "main" and the "auxiliary" frame, yieldingly connected, as will be
70 described, and referring to Figs. 1 and 2 the main frame comprises side bars or perches a , a front cross-bar a' , a rear cross-bar a^2 , made in two parts and connected between its ends by preferably a double truss, as will be described,
75 and a reach a^3 , connecting the perches and front cross-bar, the frame being preferably constructed of tubing to secure lightness, strength, and a certain flexibility—very desirable to the efficient construction of a motor-vehicle which is to travel over all kinds
80 of roads, good and bad, the parts being securely connected and held together by suitable joints or couplings to maintain its rectangular shape, while providing for flexibility.
85 The two side bars at their front ends enter slip joints or sockets a^4 , forming part of suitable T-couplings $A A'$, the latter, as herein represented, being brazed or otherwise rigidly secured to the cross-bar a' , while the
90 coupling A is loosely mounted on the cross-bar and held from lateral movement by suitable collars 2 on the bar, the side bars having at times a slight twisting movement in the joints or sockets a^4 . The reach a^3 is substantially V-shaped, as shown, and is connected
95 at or near its extremities with the side bars by pivot-bolts 3 and at its apex by a pivot-bolt 4 to the front bar a' , the pivotal connection permitting of flexure of the frame, while
100 at the same time preventing separation of the side bars and front cross-bar a' . The side

bar which enters the rigid coupling A' is at its rear end rigidly secured to a sleeve-like coupling A^2 , which loosely embraces the rear cross-bar a^2 and is prevented from lateral
 5 movement thereon by suitable collars 5, while the rear end of the other side bar is braced or otherwise rigidly secured to the rear cross-bar by a coupling A^3 .

It will be manifest that when a vehicle
 10 stands or is running over an irregular or uneven surface the several wheels cannot maintain firm contact with the ground unless there is a certain flexibility of the frame to compensate for the different levels at which the
 15 wheels stand, and this flexibility is accomplished in the present case by the construction described.

If desired and in order to secure additional strength, the tubular members of the frame
 20 may be filled with hickory or other stout elastic bars of wood.

I have herein shown the cross-bars as provided at or near their ends with like seats a^5 , those on the rear cross-bar being mounted
 25 upon the outer bearings a^6 for the driving-shaft, to be described, the several seats being slightly cupped or recessed on their upper faces and having secured thereto upright standards or rods a^7 , preferably threaded at
 30 their upper ends at a^8 , Fig. 3, to enter hollow bosses a^9 , forming parts of the straps or brackets a^{10} , secured to or constituting a part of the auxiliary frame, to be described, the threaded ends of the standards having
 35 screwed upon them retaining-nuts a^{12} to normally prevent accidental separation of the main and auxiliary frames. Spiral springs S , surrounding the standards, rest at their lower ends in the recessed seats a^9 and at
 40 their upper ends bear against the bosses a^9 to thus yieldingly support the auxiliary frame and whatever may be carried thereby.

To prevent access of dust and dirt to the springs, any suitable shield or guard may be
 45 employed, and herein I have shown each seat and the corresponding member of the auxiliary frame as provided with tubular shields a^{13} a^{15} , respectively telescoped one into the other to permit the free up-and-down relative
 50 movement of the main and auxiliary frames, while protecting the spring and other parts. Instead of such a telescopic guard it will be manifest that a flexible tube of suitable material, such as leather, could be employed.
 55 The auxiliary frame comprises side bars b , a front cross-bar b' , an auxiliary front cross-bar b^x , and a rear cross-bar b^2 , the auxiliary frame being preferably more rigidly secured together than is the main frame, as flexibility
 60 is not necessary to the same degree.

The vehicle-body B may be of any suitable shape, construction, or arrangement and is detachably mounted upon the auxiliary frame, as herein shown, the body being ordinarily adapted to conceal and protect to a
 65 greater or less extent the motor.

The driving-shaft in my present invention

is constructed substantially as described in an application, Serial No. 719,887, filed on the 9th day of June, A. D. 1899, by me and
 70 another, and comprises, essentially, outer wheel-carrying members c , to which the driving-wheels W are rigidly secured, and an intermediate crank member, herein shown as provided with two cranks c' c^2 , set quartering
 75 and with their crank-pins c^3 c^4 respectively adapted to be connected, as will be described, to the motor to be actuated thereby. The spur-gear c^5 , Fig. 2, is rotatable with the adjacent wheel W , while the bevel-gear c^6 is rotatable with the other driving-wheel, the said
 80 wheels being connected with the crank member of the driving-shaft by compensating mechanism, such as shown in the application referred to, whereby notwithstanding the fact
 85 of the intervening crank member the driving-wheels are permitted to rotate differentially, as in turning corners, and I shall not herein describe such compensating mechanism in detail, it being sufficient to say that pinions c^7
 90 and c^8 , rotatably mounted in the crank-pins and connected by a sprocket-chain c^x , mesh, respectively, with the spur-gears c^5 and c^9 , the latter being rigidly connected with one of the bevel-gears (not shown) corresponding to and
 95 placed opposite the gear c^6 , the intermediate spider C having the usual bevel-pinions to simultaneously mesh with the bevel-gears, as in the application referred to, the spider being fast on the crank member of the driving-
 100 shaft and through the compensating mechanism transmitting rotation of the shaft to the driving-wheels.

The two centrally-separated members a^2 of the rear cross-bar of the main frame are con-
 105 nected by a double truss, (shown in Figs. 1 and 2,) one member of the truss, as A^{10} , extending horizontally back of the central line of the cross-bar, while the other truss, as A^{12} , is upturned at substantially right angles to
 110 the truss A^{10} , this construction providing not only a proper space for the sweep of the cranks, but also stiffening and strengthening the back end of the frame, and the inner crank-shaft bearings are preferably mounted
 115 at the intersection of the trusses and cross-bar members a^2 .

A band-brake is shown in Figs. 1 and 2 as applied to the actuating or driving member C of the compensating mechanism. As the
 120 same is not broadly claimed herein, it will be sufficient to state that the resilient brake-band b^{50} surrounds a suitable friction-surface on the exterior of the spider C and is operated by a link b^{51} , connected to a bell-crank
 125 b^{52} , rocked by a rod b^{53} , lead to any suitable part of the vehicle, the bell-crank being mounted on the upright truss A^{12} , while the other end of the band-brake b^{50} is connected by a rod or strap b^{54} to a fixed point on the
 130 truss.

The front cross-bar a' is embraced by a collar a^{20} , having an upright sleeve-bearing a^{21} , in which is braced or otherwise suitably se-

cured a tube a^{22} , extended above and below the sleeve and preferably provided at its upper and lower ends with bushings a^{23} (see Fig. 6) for a rock-shaft a^{24} , shown as tapered at its ends at a^{25} to receive the hubs of arms a^{26} and a^{27} , respectively, the latter arm being rearwardly extended beneath the frame, while the arm a^{26} is extended from the upper end of the rock-shaft substantially at right angles to the arm a^{27} , as clearly shown in Fig. 2. Suitable retaining-nuts 26 and 27 serve to retain the arms in place on the rock-shaft.

The front cross-bar a' has pivotally mounted at its outer ends outwardly-extended wheel-spindles c^{20} , (see dotted lines, Fig. 2,) on which the front wheels C^{20} are rotatably mounted, it being understood that said spindles will rock on upright pivots, and attached to the said spindles are inwardly-inclined lever-arms c^{21} , pivotally attached at their free ends to rods c^{22} , extended toward each other and pivotally connected at their inner ends to the rear end of the arm a^{27} by a suitable bolt 33, one of said rods in Fig. 1 being shown in section. By swinging the rock-shaft a^{24} in one direction or the other the wheel-spindles will be swung bodily on their vertical fulcra, this manner of mounting steering-wheels being of well-known construction and is substantially as shown in another application, Serial No. 667,391, filed by me January 21, 1898.

The cross-bar b^x of the auxiliary frame is herein shown as provided with an upright tubular standard or support H^x , rigidly secured to a coupling B^8 , braced or otherwise fastened to the cross-bar, said standard forming a support for the steering head or post H , (shown best in Fig. 4,) made tubular and bent at its upper end to form an overhanging rearwardly-extended arm H' , the head having an external annular shoulder h to rest upon the upper end of the support H^x and maintaining the head in place vertically. The lower end of the head is shown in Fig. 4 as provided with a bushing h' , brazed in place and extending below the head with an external taper h^2 and threaded at its extremity at h^3 ; said tapered portion having forced upon it the hub of a foot h^x , (shown in dotted lines, Fig. 2,) the said foot being extended substantially in parallelism with the arm a^{26} of the vertical rock-shaft; but, as shown in Fig. 2, it is shorter than the arm a^{26} . A tubular nut h^4 , internally threaded at h^5 and provided with a vertical lip or feather h^6 , is screwed tightly upon the threaded end h^3 of the bushing h' and aids in maintaining the foot h^x firmly in place, said nut receiving upon it a sleeve H^5 , provided with a vertical slot 40 to receive the lip or feather h^6 of the tubular nut h^4 . The sleeve H^5 is also provided exteriorly with two parallel segmental lips h^7 to form between them a guideway h^8 (see Fig. 4) for a purpose to be described, the lower end of the sleeve being threaded at h^9 ; but the threaded part h^9 of the sleeve is cut oppositely to the threaded part h^5 of the nut h^4 ,

the two threaded portions referred to engaging an internal double-threaded nut N^x , having right and left hand threads to correspond to the two parts referred to. Referring to Fig. 5, this double-threaded nut N^x is connected, as by a spline n^x , with a shaft h^{10} , extended through the vertical portion of the steering-head and also below the lower end of the sleeve H^5 , as clearly shown in Fig. 4, so that the nut N^x will rotate when the said shaft is rotated; but the latter may be moved longitudinally relatively to the double-threaded nut. By rotation of the nut the sleeve H^5 is slid up or down upon the nut h^4 , the double threading effecting a greater vertical movement of the sleeve for a given amount of rotation of the shaft h^{10} than with a single thread. The segmental guideway h^8 of the sleeve engages a bell-crank r^x , Fig. 1, mounted on a suitable bracket on the auxiliary frame, said bell-crank being connected by a rod r with a second bell-crank r' , mounted upon the motor, to be described, this latter bell-crank in turn being connected by a rod r^2 with a lever r^3 to control the throttle T of the motor, in the present instance of my invention, as I have shown, a steam-motor, but any other speed-controlling device for a motor could be operated by connection with the sleeve H^5 without departing from my invention. A second bell-crank lever t , Fig. 1, is connected by a link t' to a second bell-crank t^2 , which in turn operates a reversing device R for the motor, such reversing device being of any well-known or usual construction and forming no part of this invention. The bell-crank t is jointed to the lower end of the shaft h^{10} , and manifestly longitudinal movement of said shaft will in the present instance control the reversing device of the motor, while rotative movement of said shaft will control the speed-regulating device for the motor. A mere reversal of these parts is clearly within the spirit and scope of my invention, for if desirable or necessary the longitudinal movement of the shaft could be made to regulate the speed and the rotative movement to effect reversal of the motor. The overhanging arm H' is provided with a rotative longitudinally-extensible member H^2 , provided at its outer end with a suitable hand piece or grip H^3 , a cap h^{12} at the end of the arm forming a bearing for said extensible member, while at its inner end the member is provided with a bearing-block h^{13} , shown as substantially barrel-shaped, so that it will slide freely in the overhanging arm and at the same time form a support for the inner extensible member H^2 . The inner end of this member is connected with the upper end of the shaft h^{10} by any suitable flexible connection of such a character that rotative movement of the member H^2 will be imparted to the said shaft. The upper end of the shaft is shown in Fig. 4 as provided with a cylindrical bearing-block h^{14} , and the flexible connection herein shown is very simple, strong, and effective, and it

comprises, essentially, a series of bearing-blocks e , substantially shaped exteriorly like the block h^{13} and provided with holes at each end to receive the bent ends of connecting-links e' . Each link is made of strong heavy wire, it may be with one end, as e^2 , bent laterally to enter one of the bearing-blocks, while its other end, as e^3 , is also bent laterally but at right angles to the end e^2 . The end e^3 loosely enters the next bearing-block, and two blocks are thus connected by a link with a species of universal joint, so that while rotation of the extensible member H^2 will be transmitted by this connection to the shaft h^{10} said connection will be sufficiently flexible to travel around the curved portion of the steering-head, between it and the lower end of the overhanging arm H' . The member H^2 constitutes a controller for the vehicle, whereby the latter can be steered, its speed regulated, and its direction of movement forward or backward controlled. By swinging the controller to the right or left it will be obvious that the steering-head will be rocked in its vertical support to steer the vehicle, the foot h^x being connected with the arm a^{26} by a link a^{30} , and by rotative and longitudinal movement of the hand-controller the speed and direction of movement of the vehicle forward or backward will be controlled. This particular feature herein shown is not broadly claimed, as it forms a part of the subject-matter of my application, Serial No. 667,391, referred to.

The steering-head is mounted on the auxiliary frame, which in the present embodiment of my invention is yieldingly connected with the main frame, and the vertical rock-shaft a^{24} is mounted on the latter frame, so that it is necessary to provide great freedom of movement between the foot h^x of the steering-head and the arm a^{26} . For this purpose the link a^{30} is connected with the said arm and foot, respectively, by ball-and-socket joints of any suitable description, the outer end of the arm a^{26} , as shown in Fig. 1, having an up-turned projection 45, terminating in a ball, (not shown,) while the end of the link a^{30} forms one part of the socket, a cap 46 being bolted thereto around the ball to hold the socket part in place. The other end of the link a^{30} is provided with a similar socket member 47, and the foot h^x has a depending pin 48, with a ball end to enter the socket member of the link. This connection provides for all of the various relative movements of the main and auxiliary frame without interfering in the least with the steering of the vehicle.

Referring to Fig. 1, a motor is therein represented, and it may be substantially such a motor as shown in my United States Patent No. 601,218, granted March 22, 1898, and comprising a boiler M , having an attached offset casing M' , in which are located the cylinders, I preferring to use a plurality of cylinders, the piston-rods P of two cylinders being shown in Fig. 1, the boiler being of the vertical type,

and it is provided with rigid web-like brackets or standards M^x at its sides to support a transverse brace m^x , (see Fig. 2,) the ends of the brace being extended beyond the brackets and made spherical, as at m , (see dotted lines, Fig. 2,) to enter socket members m' of distance members, shown as longitudinally-rigid rods m^2 , rearwardly extended toward the back of the vehicle and transversely jointed at m^3 to ears m^4 on collars m^5 , rigidly secured to the upturned ends of the truss A^{12} . The motor is yieldingly supported in any suitable manner relatively to the vehicle-wheels, and herein I have shown the motor as adapted to be carried by the auxiliary frame, and the distance members described serve to maintain a constant distance between the motor or the actuating members thereof (to be referred to) and the crank driving-shaft of the vehicle, while permitting by the jointed connections referred to the up-and-down movement of the motor relatively to the shaft, and also permitting rocking or tipping movement or any resultant of such movements. The reciprocations of the piston-rods of the motor are transmitted to like rocking members M^2 , shown as bell-cranks fulcrumed side by side at m^6 in bearings m^7 , connected by struts m^8 with a suitable bracket m^9 , bolted or otherwise secured to the cylinder-casing M' , the short connecting-rods P' between the piston-rods and the upper arms of the rocking actuators being shown in dotted lines, Fig. 1.

A convenient construction for the actuators is shown on a larger scale in Figs. 7 and 8, the said actuators being formed of two parallel bell-crank or two-armed plates m^{12} , connected by a hub or bushing m^{13} at their fulcrum-point, the extremities of the depending arms being connected by a pin m^{14} , (see Fig. 8,) having a nearly-spherical central portion m^{15} , which is embraced by the two members 50 and 51 of a box, forming a socket member, securely connected by suitable bolts 52, the socket members or boxes being in turn attached to one end of the connecting-rods M^{12} , interposed between the actuators and the crank-pins of the driving-shaft, the bolts 52 not only connecting the two parts of the socket member, but also passing through the upset or flattened end m^{150} of the connecting-rod. This construction described provides one form of universal joint between the connecting-rod M^{12} and its corresponding actuator, and, as most clearly shown in Figs. 2 and 9, the other end of the connecting-rod is also universally jointed to the crank-shaft. Referring to Fig. 9, one of the crank-pins, as c^3 , is shown in section and embraced by the two parts 60 and 61 of the box, the said parts of the box being connected and held in place by suitable bolts 62, which latter also pass through caps 63, the latter retaining in place the T-shaped end m^{150} of the connecting-rod, which is rounded to form journals having bearings in a semicylindrical recess 64 in the part 60 of the box and a corresponding recess

in the caps 63, the T end m^{150} of the connecting-rod being set at right angles to the crank-pin. This connecting of the rod with the crank-shaft forms another species of substantially-universal joint, and by attaching the longitudinally-rigid connecting-rods m^{12} to the actuating members of the motor and to the crank-shaft, respectively, I make provision for the lateral up-and-down and rocking movements which may beset up relatively between the motor and the crank-shaft, and I obtain all of the advantages of a direct connection between the motor and driving-shaft by combined tension and compression members, while at the same time adapting such mechanism to a motor-vehicle of the character described.

A flexible power-transmitting connection between the motor and driving-shaft, as by a sprocket-chain, has a number of advantages, as such construction admits of great flexibility of the different parts; but the disadvantages are also numerous, as a chain is expensive, wears out with considerable rapidity, and is also apt to be thrown considerably out of its proper or theoretical path of travel by the relative movement of different parts of the vehicle in traveling over rough roads. The direct mode of connection is simpler, cheaper, and more powerful and by my invention has substantially the important feature of flexibility. With such connection the necessity of maintaining a fixed distance between the motor and the driving-shaft will be manifest and the utility of the distance members hereinbefore described will be obvious.

While I have herein shown one practical embodiment of my invention, various changes in the construction and arrangement may be made without departing from the spirit and scope of my invention, for, so far as I am aware, it is broadly new to provide a universally-jointed and direct connection between the motor and the driving-shaft of a road-vehicle, the term "direct connection" being used herein in contradistinction of the use of a belt, band, chain, or other endless flexible device.

Among the advantages accruing from the use of a vertical-acting motor, such substantially as herein shown, one of the most important is the reduction or neutralization of the vibrations which the operation of the motor tends to set up, as the vibrations of the vertical and horizontal acting members to a very considerable degree operate against each other. Again, the close proximity of the engine proper to the steam-generator shortens the necessary steam passages or connections, thereby reducing to a minimum the condensation due to such connections, and by its elevated position the engine is farther removed from and better protected from the action of the dust of the highway over which the vehicle travels.

Having described my invention, what I

claim as new, and desire to secure by Letters Patent, is—

1. In a motor-vehicle, a flexible frame, a crank-shaft provided with driving-wheels and mounted on the frame, a motor, and connecting means between the motor and crank-shaft, universally jointed to each. 70

2. In a motor-vehicle, a crank-shaft provided with driving-wheels, a motor, actuating connecting means between the motor and crank-shaft, universally jointed to each, and means to maintain a constant distance between the motor and the crank-shaft. 80

3. In a motor-vehicle, a crank-shaft provided with driving-wheels, a yieldingly-supported motor, direct and longitudinally-rigid connections between and universally jointed to the motor and crank-shaft, and means to maintain a constant distance between the motor and the crank-shaft while permitting their relative movement. 85

4. In a motor-vehicle, a crank-shaft provided with driving-wheels, compensating mechanism connective of said shaft and wheels to permit differential rotation of the latter, a motor, and direct connecting means between the motor and crank-shaft, universally jointed to each. 95

5. In a motor-vehicle, a crank-shaft provided with driving-wheels, compensating mechanism connective of said shaft and wheels to permit differential rotation of the latter, a motor, direct connecting means between the motor and crank-shaft universally jointed to each, and means to maintain a constant distance between the motor and crank-shaft while permitting their relative movement. 105

6. In a motor-vehicle, a crank-shaft provided with driving-wheels, compensating mechanism connective of said shaft and wheels to permit differential rotation of the latter, a yieldingly-supported motor, direct actuating means between the motor and crank-shaft universally jointed to each, and means to maintain a constant distance between the motor and the shaft while permitting relative movement thereof. 115

7. In a motor-vehicle, a flexible frame, steering and driving wheels mounted upon the frame, a crank-shaft to actuate the driving-wheels, a motor, longitudinally-rigid actuating means between the motor and crank-shaft and universally jointed to each, and distance members jointed respectively to the motor and crank-shaft bearings, to maintain a constant distance between the motor and crank-shaft. 125

8. In a motor-vehicle, a motor provided with rocking transmitting members, a crank-shaft provided with driving-wheels, connecting-rods between and universally jointed to the crank-shaft and rocking members of the motor, and means to maintain a constant distance between the motor and crank-shaft while permitting relative movement thereof. 130

9. In a motor-vehicle, a main frame, a driv-

- ing-shaft mounted thereupon and provided with driving-wheels, an auxiliary frame yieldingly connected with the main frame, a motor on the auxiliary frame, actuating connections between the motor and driving-shaft
- 5 universally jointed to each, and means to maintain a constant distance between the motor and the driving-shaft while permitting relative movement of the main and auxiliary
- 10 frames.
10. In a motor-vehicle, a frame, a truss mounted thereon and provided with bearings, a crank driving-shaft mounted in said bearings and provided with driving-wheels, a
- 15 yieldingly-supported motor, and actuating connections between the motor and crank-shaft and universally jointed to each.
11. In a motor-vehicle, a main frame provided with steering and driving wheels, up-
- 20 right standards on the main frame, an auxiliary frame provided with devices to engage and move vertically upon said standard, supporting-springs interposed between the main and auxiliary frames to yieldingly support
- 25 the latter, retaining devices to prevent accidental removal of the auxiliary frame, a motor on the latter, and connections between the motor and driving-wheel to actuate the latter.
12. In a motor-vehicle, driving and steering
- 30 wheels, a frame yieldingly supported on said wheels, a motor and a steering-head carried by the frame, operative connections between the motor and driving-wheels, and between the steering-head and the steering wheel
- 35 or wheels, and a detachable body mounted on the frame independently of the steering and motive mechanisms of the vehicle.
13. In a motor-vehicle, a flexible frame provided with a driving-shaft and wheels, a
- 40 yieldingly-supported motor and an independent detachable body, both adapted to be carried by the frame, and actuating connections between the motor and the driving-shaft.
14. A flexible frame for motor-vehicles,
- 45 comprising side bars, front and rear cross-bars, the side bars having slip connections with the front cross-bar, a reach pivotally connected with the side bars and front cross-bar to prevent their separation, bearings carried
- 50 by the rear cross-bar, and a driving-shaft mounted therein, and a steering wheel or wheels for the vehicle operatively mounted on the front cross-bar.
15. A flexible frame for motor-vehicles
- 55 provided with driving-wheels, a front cross-bar forming a part of said frame, and wheel-spindles pivotally mounted upon said bar, a vertical rock-shaft mounted upon the said cross-bar and having a rearwardly-extended
- 60 rigid arm, connecting-rods jointed to said arm and to the spindles to swing the latter, a second arm extended from the rock-shaft at an angle to the rearwardly-extended arm, a steering-head yieldingly supported relatively
- 65 to the frame, and a jointed connection between the head and said second arm, to
- steer the vehicle by movement of the steering-head.
16. A motor-vehicle having a main frame provided with driving-wheels, a front cross- 70 bar forming a part of said frame, and wheel-spindles pivotally mounted thereupon, a vertical rock-shaft mounted upon said bar, a rearwardly-extended arm fast on the shaft, connecting-rods jointed respectively to the 75 spindles and to the said arm, a second arm on the rock-shaft, an auxiliary frame yieldingly connected with the main frame, a steering-head mounted on the auxiliary frame and having a laterally-extended foot, and a link 80 universally jointed to said foot and to the second arm of the rock-shaft to steer the vehicle by rotative movement of the steering-head.
17. In a motor-vehicle, steering and driving 85 wheels, a crank-shaft to actuate the driving-wheels, a yieldingly-supported body, a motor movable therewith, connecting-rods between the motor and crank-shaft and universally jointed to each, to rotate said shaft, 90 means to maintain a constant distance between the motor and crank-shaft, a steering-head mounted to move with the body, and connections between said head and the steering-wheels to control the latter. 95
18. A frame for motor-vehicles comprising side, and front and rear cross-bars, the rear cross-bar being made in two parts, a double truss rigidly connecting the parts of said bar and provided with bearings, a crank driving- 100 shaft mounted in said bearings, driving-wheels connected with said shaft, steering-wheels carried by the frame, and a yieldingly-supported steering-head operatively connected with and to control the steering-wheels. 105
19. In a motor-vehicle, a crank driving-shaft provided with wheels, a yieldingly-supported motor comprising a vertical boiler and cylinders, rocking transmitting members, longitudinally-rigid connecting-rods universally 110 jointed to the transmitting members and the crank-shaft to rotate the latter, and distance-rods jointed to the motor and crank-shaft support to maintain a constant distance between the motor and crank-shaft. 115
20. In a road-vehicle, a main frame provided with wheel-spindles pivotally mounted thereupon, an arm set at an angle on each spindle, and rods jointed to the extremities 120 of the said arms, combined with an auxiliary frame yieldingly connected to the main frame, a tubular upright support on the auxiliary frame, a steering-head rotatable in said support and having at its lower end a rigidly-attached foot, a vertical rock-shaft provided 125 with a rearwardly-extended arm jointed to the inner ends of the rods connected with the spindles, and connections between the foot of the steering-head and the rock-shaft to rock the wheel-spindles by rotative movement of the steering-head. 130
21. In a road-vehicle, propelling mechan-

ism, speed-regulating and reversing devices therefor, a rotative steering-head having an overhanging arm at its upper end, a transverse segmental guideway vertically movable on and carried by the lower portion of the head to turn therewith, a right and left hand threaded nut in continuous engagement with the guideway and with a threaded portion of the steering-head, operative connections between one of the propulsion-controlling devices and said guideway, operated by vertical movement of the latter, a hand-controller carried by the overhanging arm and adapted to be rotated and also longitudinally moved, a rotatable longitudinally-movable shaft in the head and connected with and to rotate the threaded nut, a flexible connection between the shaft and the hand-controller, and connections between the other of said propulsion-controlling devices and the shaft, operated by longitudinal movement of the latter.

22. In a road-vehicle, propelling mechanism, speed-regulating and reversing devices therefor, a rotative steering-head having an overhanging arm at its upper end, a hand-controller carried by the overhanging arm and adapted to be rotated and also longitudinally moved, connections between the propulsion-controlling devices and said shaft, one of said devices being actuated by longitudinal and the other by rotative movement of the said shaft, and a flexible connection between the shaft and the hand-controller, said connection comprising a plurality of rocking bearing-blocks supported within the arm and head, and links between adjacent blocks jointed to the latter, the joint with one block being substantially at right angles to the joint with the adjacent block.

23. In a road-vehicle, propelling mechanism, speed-regulating and reversing devices therefor, a rotative steering-head having an overhanging arm at its upper end, a hand-controller carried by the overhanging arm and adapted to be rotated and also longitudinally moved, a shaft in the head, connections between the propulsion-controlling devices and said shaft, one of said devices being actuated by longitudinal and the other by rotative movement of the said shaft, and a flexible connection between the shaft and the hand-controller, said connection comprising rounded bearing-blocks adapted to slide and rock within the head and overhanging arm, and links connecting adjacent blocks, said links being bent at right angles at their opposite ends and inserted in holes in the blocks, the end of one link being substantially at right angles to the end of another link connected to the same block.

24. In steering mechanism for motor-vehicles, a tubular steering-head having an overhanging arm, a rotative and longitudinally-movable controlling member mounted in the arm, a shaft in the head, and a flexible connection between said shaft and controlling

member, comprising a plurality of rocking bearing-blocks supported within the head and arm, and connecting-links between adjacent blocks and jointed thereto, the joint with one block being substantially at right angles to the joint with the adjacent block.

25. In a motor-vehicle, a crank member, a substantially vertically acting motor, means to convert the substantially-vertical action thereof to a substantially-horizontal action, and a longitudinally-rigid universally-jointed power-transmitting connection between said converting means and the crank member.

26. In a motor-vehicle, a crank member, a substantially vertically acting, yieldingly-sustained motor, means to convert the substantially-vertical action thereof to a substantially-horizontal action, and a longitudinally-rigid universally-jointed power-transmitting connection between said converting means and the crank member, and a longitudinally-rigid universally-jointed means to maintain a substantially-constant distance between said motor and the crank member.

27. In a motor-vehicle, a frame, a crank-shaft fixedly positioned thereon, and provided with propelling-wheels, steering-wheels connected with the frame, the side bars of the latter maintaining a fixed distance between the shaft and steering-wheel connections, a body yieldingly connected with the frame, a motor mounted to partake of its movements, actuating connecting means between the motor and crank-shaft, universally jointed to each, and means to maintain a constant distance between the motor and crank-shaft while permitting yielding movements of the motor with the body.

28. In a motor-vehicle, a frame provided with laterally-separated shaft-bearings, a crank-shaft rotatably mounted in said bearings and having its crank members located between the latter, propelling-wheels operatively connected with the shaft, a body yieldingly connected with the frame, a motor mounted to partake of the movements of the body, reciprocating power-transmitting members between the motor and crank members of the shaft, and means to maintain a substantially-constant operative distance between the crank-shaft and motor while permitting yielding movements of the motor with the body.

29. In a motor-vehicle, a frame having shaft-bearings at one end, a crank-shaft mounted in said bearings and having its crank members located between the latter, propelling-wheels operatively connected with the ends of the crank-shaft, a body yieldingly connected with the frame, a steam-motor mounted on the body and including cylinders located adjacent its longitudinal center, power-transmitting means, including universally-jointed connecting-rods, between said motor and the crank members of the shaft, and means to maintain a substantially-constant distance between the crank-shaft and motor.

30. In a motor-vehicle, a frame provided with laterally-separated shaft-bearings, a crank-shaft rotatably mounted in and having its crank members located between said bearings, propelling-wheels, compensating mechanism connective of said wheels and shaft, a body yieldingly supported on the frame, a motor mounted to partake of the movements of the body, longitudinally-rigid, parallel distance-rods jointed to said motor and adjacent the shaft-bearings, to maintain the motor and shaft a substantially-constant distance apart while permitting yielding movements of the motor with the body, and reciprocating power-transmitting members operating between said distance-rods and universally connected with the motor and the crank members of the shaft.

31. In a motor-vehicle, a frame, a crank-shaft mounted in bearings on said frame and provided with driving-wheels, compensating mechanism, means to transmit the differential action of said compensating mechanism through the crank of said shaft, a truss member of the frame to support said shaft on opposite sides of the crank, a yieldingly-supported body, a motor mounted on said body, longitudinally-rigid universally-jointed connecting-rods to transmit power from the motor to said crank-shaft, and means to maintain a constant distance between the motor and crank-shaft.

32. In a motor-vehicle, a frame including a transversely-arranged truss, outer bearings carried by the frame, and inner bearings in alinement therewith, carried by the truss, and a crank-shaft the crank portion whereof is

located between the inner, truss-supported bearings.

33. In a motor-vehicle, propelling-wheels, a substantially vertically acting motor, a crank-shaft operatively connected with and to rotate said wheels, substantially horizontally acting connecting-rods connected with and to rotate said crank-shaft, and bell-crank levers interposed between and connecting said motor and said connecting-rods, to operate as described.

34. In a motor-vehicle, propelling-wheels, and a crank-shaft connected with and to drive the same, a substantially vertically acting engine including reciprocating piston-rods, bell-crank levers to which the piston-rods are connected, and substantially horizontally acting connecting-rods joining said bell-crank levers and crank-shaft.

35. In a motor-vehicle, propelling-wheels, a crank-shaft connected with and to drive the same, a substantially vertically acting engine, substantially horizontally acting connecting-rods, and bell-crank levers connecting the piston-rods of said engine with said connecting-rods, the horizontal arrangement of the latter permitting rise and fall of said motor with reference to said crank-shaft, without disturbing the operative connection of the two.

In testimony whereof I have signed my name to this specification in the presence of two subscribing witnesses.

GEORGE E. WHITNEY.

Witnesses:

GEORGE B. UPHAM,
NATHANIEL H. COOLEGE.