

No. 755,202.

PATENTED MAR. 22, 1904.

G. E. WHITNEY.
FLASH BOILER.

APPLICATION FILED DEC. 20, 1902.

NO MODEL.

2 SHEETS—SHEET 1.

Fig. 1:

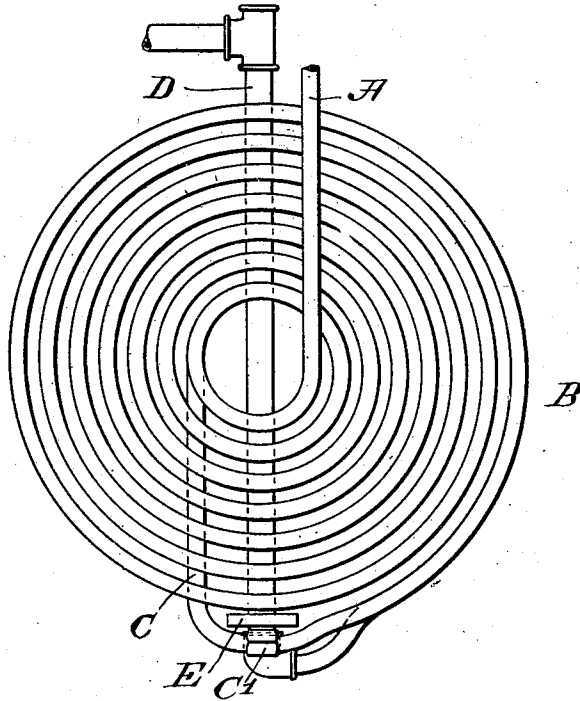
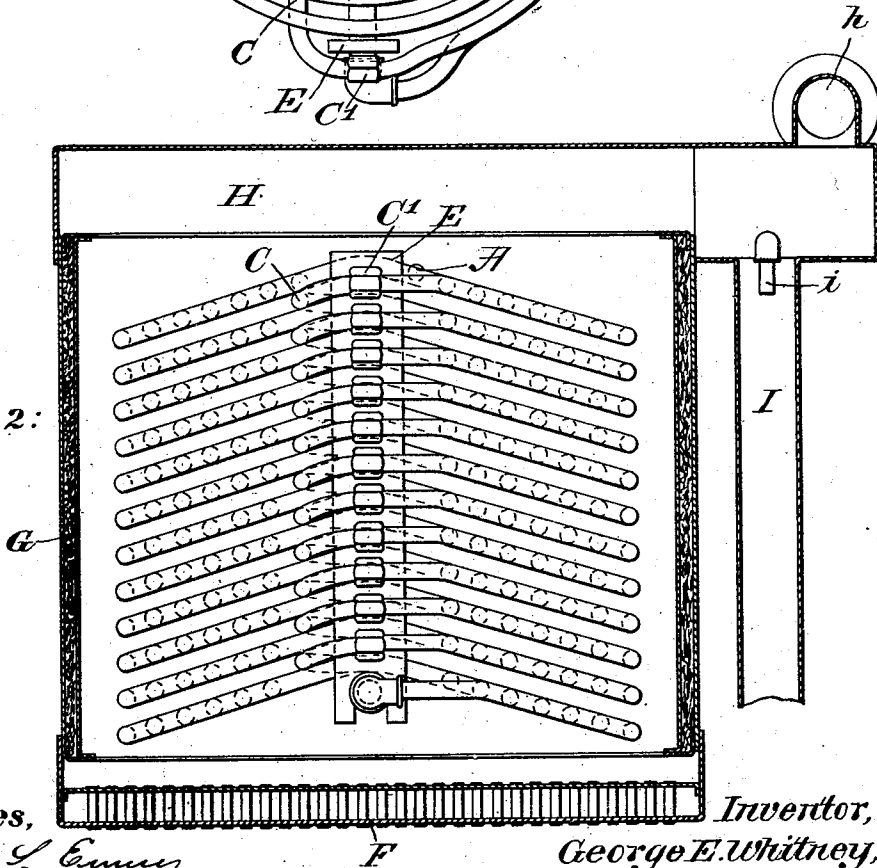

Fig. 2:



Witnesses,
Ernest L. Emery
A. E. Chuley

Inventor,
George E. Whitney,
 by *Ernest L. Emery*
Att'y.

No. 755,202.

PATENTED MAR. 22, 1904.

G. E. WHITNEY.
FLASH BOILER.

APPLICATION FILED DEC. 20, 1902.

NO MODEL.

2 SHEETS—SHEET 2.

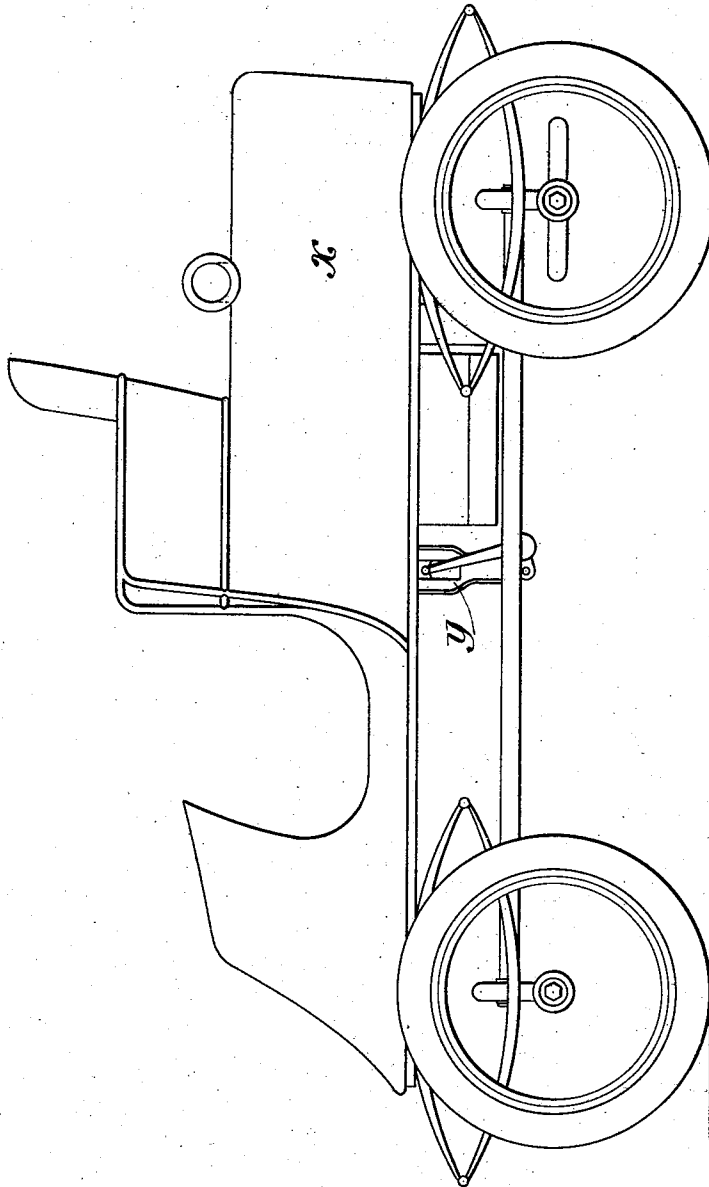

Fig. 3:

Witnesses,
Ernest S. Emery
A. E. Chesley

Inventor,
George E. Whitney,
by Ernest S. Emery
Atty.

UNITED STATES PATENT OFFICE.

GEORGE E. WHITNEY, OF BRIDGEPORT, CONNECTICUT, ASSIGNOR TO
WHITNEY MOTOR WAGON COMPANY, OF KITTERY, MAINE, A COR-
PORATION OF MAINE.

FLASH-BOILER.

SPECIFICATION forming part of Letters Patent No. 755,202, dated March 22, 1904.

Application filed December 20, 1902. Serial No. 136,010. (No model.)

To all whom it may concern:

Be it known that I, GEORGE E. WHITNEY, a citizen of the United States, residing at Bridgeport, in the county of Fairfield and State of Connecticut, have invented an Improvement in Flash-Boilers, of which the following description, in connection with the accompanying drawings, is a specification, like letters on the drawings representing like parts.

This invention relates to what are known as "flash-boilers," and refers particularly to that class of flash-boilers in which the water in the several coils is so trapped that water entering the topmost coil cannot gravitate to the bottom coil through the intermediate series.

The invention has for its object, further, a simple and economical construction, which may be especially adapted for use in connection with motor-vehicles.

My invention will best be understood from a description of a boiler illustrating one embodiment thereof.

In the accompanying drawings, Figure 1 is a plan view of the generating-coils of a boiler, illustrating one embodiment of my invention; Fig. 2, a side elevation thereof, and Fig. 3 a side elevation of a motor-vehicle equipped with said boiler.

In the particular embodiment of my invention selected for illustration herein and shown in the drawings a series of superimposed and preferably circular coils B is provided, the top coil of which is connected by a pipe A with a source of water-supply. This inlet-pipe A passes to the center of the coil. The outermost portions of each coil are connected by pipes C with the centers of the coils next below. As indicated in Figs. 1 and 2, a suitable baffle-plate E is provided at one side of the superimposed coils to protect the couplings C' in the pipes C. The outer portion of the lowest coil is connected by a suitable coupling with a dry-pipe D, which conducts the generated steam to the motor.

As shown in Fig. 2, each of the series of coils is bent downwardly at each side of a diametral line, so that the portions of said coils at opposite sides said line stand in inclined

planes. These coil portions formed by undulating or bending the axis of the coil may be called "lineal" portions, meaning portions of a given length and of the full cross-sectional diameter of the pipe or conduit. By this arrangement it will readily be seen that the water at one side said diametral line cannot gravitate to the opposite side thereof. Hence the water admitted to or formed by condensation in said coils will remain therein on either side of said line except it be forced toward the bottom coils by the delivery of steam therefrom.

In the operation of my invention heat is applied below the coils, as by a burner F, and as the water flows to the lower and hotter coils it is gradually heated until at some intermediate point it is converted into steam and in the further flow downward becomes further heated by the most heated coils next the fire, and is finally conducted by the pipe D to the motor, typified at Y.

By my invention, one embodiment of which is herein shown, the superposed coils may be and are here shown as directly connected one with the other and without the interposition of traps, since the traps are formed in and by the coils themselves, and as there are as many traps as there half-convolutions in the bent or deflected coils, it is clear that the number of trapped boiler-sections is largely increased and the benefits due to trapping correspondingly increased.

When used in a motor-vehicle, the diametral lines along which the coils are bent or deflected are preferably arranged longitudinally of the vehicle, but not necessarily so.

In Fig. 2 the boiler is shown arranged in a suitable inclosing case or shell G, below which is a suitable or usual hydrocarbon-burner F for heating the coils of the boiler, the casing being surmounted by a bonnet or hood H, having suitable or usual draft-outputs—such, for instance, as the updraft *h* and the downdraft I, with the engine-exhaust arranged in the latter to create a downdraft therein.

For clearness of illustration in Fig. 2 the

up and down draft outlets are shown at the side of the boiler; but in practice they will preferably be at the rear of the boiler, as shown in Fig. 1, the operation being precisely the same.

Variations may be made in the details of my invention without departing from the spirit thereof.

I claim—

- 10 1. A steam-generator containing a series of connected superposed generating-coils, each of uniform bore throughout, at least one of said coils having a portion higher than another portion which is nearer the inlet end thereof.
- 15 2. A steam-generator containing a series of superposed generating-coils, at least one of which has a portion higher than another portion which is nearer to the inlet end thereof, connections between said coils and a baffle-plate protecting said connections.
- 20 3. A steam-generator containing a series of superposed generating-coils connected in series and approaching a source of heat whereby the water is heated progressively, one or more
- 25 of said coils having a portion higher than another portion which is nearer to the inlet end thereof, connections between said coils, and protecting means for said connections.
- 30 4. A steam-generator containing a series of connected coils, each depressed on opposite

sides of a diametral line to resist gravitation of water therethrough.

5. In a steam-generator, a helical generating-coil the axis of which occupies different levels at different points.

35

6. A steam-generator containing a generating-conduit of helical formation, the axis whereof occupies different levels at different points.

7. A steam-generator containing a generating-coil, parts of the axis of a plurality of convolutions of which lie in a different plane from that of other parts of said axis.

40

8. In a steam-generator a series of superposed generating-coils, lineal portions of each coil being trapped one from another.

45

9. In a steam-generator a series of superposed generating-coils, one or more having undulatory axis or axes.

10. In a steam-generator a series of superposed generating-coils, at least one of which presents a lineal portion at a higher level than another lineal portion.

50

In testimony whereof I have signed my name to this specification in the presence of two subscribing witnesses.

GEORGE E. WHITNEY.

Witnesses:

VICTOR LINDEROTH,
THOMAS B. TAYLOR.